

SCHNEIDER SERVOHYDRAULIC

Digital axis controller type HE 304

Description

The digital axis controller HE 304 is a μ C-based regulator with analogue, digital, sensors and bus in-and outputs in a standard European size format. He is useable for all electro hydraulic axis and all fast regulators in industrial und testing applications.

Application areas are as

- Electro hydraulic axis
- Position control
- Parallel control
- Force/ pressure controls
- Force control with subordinated position control
- Position control with delimited force



An analogue exit is directly suitable for the current control of the servo valves. A digital sensor input is laid out as SSI and/or start-stop interface for common position sensors. According to a standard CAN bus, optionally still another field bus connection as Profibus, EtherCAD or Interbus are present. With the HE 304 1(2) hydraulic servo axis can be regulated. With the Windows® program HyperTerminal (included in each Windows system) the parameter to the controller can be set. On request the software can be adapted customized. (E.g. desired value process; limit switching points; drive external devices etc.

Execution variants

A 19-zoll base board carries the system board, LEDs for the indication of the digital in- and outputs, test points and additional. The controller is also delivery in a terminal junction box for field applications or as rail mountable module under the type model HE 303.

Bloc diagram

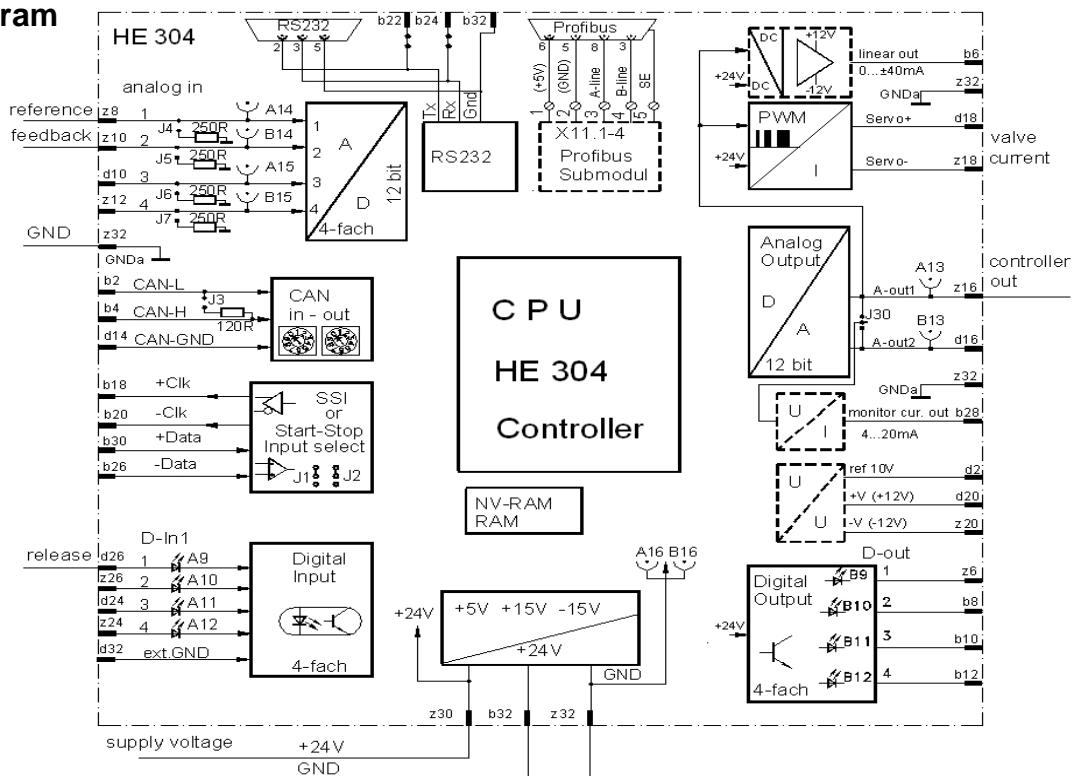

Technical data

Supply

Power supply : 24V DC ($\pm 15\%$) approx. 500mA

Inputs

Digital

- 1) Digital Inputs Din 1 - 4 : 24 Volt opto isolated
 Input current = 10 mA
 1-Signal $U_e > 12\text{ V}$ 0-Signal $U_e < 5\text{ V}$
- 2) SSI, SST (Start/Stop) input for position sensors
 : transmit $I_{\max} = \pm 60\text{ mA}$
 receivers sensitivity $\pm 200\text{ mV}$
- 3) CAN-Bus-input
 : $U_{\text{CAN}} = -5 \dots +18\text{ V}$
 : $U_{\text{diff}} = 1,5 \dots 3\text{ V}$, short circuit resistance
 max Baud-rate: 500kBaud
 terminal resistance 120 Ohm; pluggable
- 4) Profibus-Slave input : (with optional add-on board)
 according to Profibus-DP EN 50170 (DIN 19245)
- 5) Programming interface : RS 232 via 9 pin D-SUB modem cable
 : transmit voltage = $\pm 8\text{ V} / \pm 22\text{ mA}$
 : input voltage low/high = 1,3 / 1,8V

Analogue

- 6) Analogue input 1 - 4 : 12 bit resolution
 Voltage range 0...+5V; 0...+ 10V; $\pm 5\text{ V}$; $\pm 10\text{ V}$ selectable; $R_{\text{in}} 30\text{ kohm}$
 Current range 0 / 4 – 20mA pluggable (with Jumper J4 ... J7)
 $R_{\text{in}} 250\text{ Ohm}$

Outputs

Digital

- 1) Digital output Dout 1 - 4 : 24 Volt / 500 mA,
 short circuit resistance, with reference to internal GND

Analogue

- 2) Analogue voltage Aout1 / 2 : 0... ± 10 Volt, 12 bit resolution
 $I_{\max} 5\text{ mA}$; short circuit resistance
- 3) Current monitor output : 0 / 4 – 20mA (option on output pin b28)
 $U_{\max} 20\text{ V}$
- 4) PWM current booster : for servo valve with dither
 possible rated currents : 0 ... $\pm 200 / \pm 300 / \pm 650 / \pm 1000\text{ mA}$
 Short circuit proof, 12bit resolution
- 5) Linear low current : low level signal output for Flapper valves (option on output pin b6)
 : 0 ... $\pm 40\text{ mA}$ to GND
 $U_{\max} \pm 12\text{ V}$

Controller

Microcontroller 16 bit : Siemens C167 with 20 MHz
 Controller scan time : 1 msec with watchdog control
 Parameter interface : with RS232
 Storage capacity : Flash EPROM 256 x 16
 NVRAM 2 x 32k x 8

Mechanical data's

Dimensions: European size card 100 x 160 mm
 Front plate 50 mm (10 TE) 3 HE

Connector: male DIN41612 F 48 pin

Weight 500 g

Environment

Permissible ambient temperature	: -10 ... +65 °C
Storage temperature	: -40 ... +85 °C
Permissible humidity	: 30 ... 75 % not condensed
Shock resistance	: < 2g sinus form 10 ... 100Hz
EMC level	: 3 according to EN 50082-2
(Only if the board is mount in an EMC protected rack)	
Protection class	: IP 20

Model Type and order codes

12362	HE 304- XXXX - 5	01	00	1	-	1 A	
Order-no	Type 304	Current xxxx 0200 0300 0650 1000	Front-type 0 = without 3 = 8TE 4 = 5 = 10TE	Software-type 00 = basis 30 = standard 31 = ... 99 = customized	Add-on boards 0 = without 1 = Profibus 2 = external CAN-open 3 = RS 232 4 = +/-12V & RS232 5 = Profibus 9pol D-SUB 6 = EtherCAD 7 = TF-Modul	Hardware design 00 = Standard board F48 pol ..01 = Monitor output 4...20mA von DA2 02 = Monitor output 0...±20mA von DA2 03 = Monitor output 4...20mA von DA2 and Flapper current output ..04 = Flapper current output	Construction level 0A = 3/2003 1A = 10/2009

executed samples

Order no	type	description
12362	HE 304-xxxx-5-30-00-0-1A	Standard
11476	HE 304-0000-5-01-00-0-1A	two channel Bypass-pressure control
14099	HE 304-0000-5-03-00-0-1A	pressure control with CAN interface
40067	HE 303-xxxx-3-05-01-0-0A	Position control with 8 TE front plate
1017031	HE 304-xxxx-5-14-00-6-1A	EtherCAD force control
1054527	HE 304-xxxx-3-17-03-0-1A	Position control with Monitor-/ Flapper-current output
1058961	HE 304-xxxx-5-17-03-5-1A	Profibus controller with Monitor-/ Flapper-current output

Additional parts

37946	KE DIN41612-F48	Female connector soldering type
18499	KE DIN 41612-F48pol WW	Female conn. with WW-terminal points 1x1 mm for rack mounting
37747	KE SKBI 64/F48	Card holder with terminal screws
1065101	HE 236-PS-1AC-24DC-0.75FL	Power supply 18W 24V DC 0,75A DIN rail mounting

Connection

on the connector DIN 41612 F48 pin:

Power supply

z30 +24V
b32, z32 GND

CAN Bus

b2 CAN-L
b4 CAN-H
d14 CAN-GND

SSI or SST Sensor input:

b30 Rx+; Data+; Start-Stop
b26 Rx-; Data-; /Start-Stop
b18 Tx+; Clk+; Init
b20 Tx-; Clk-; /Init
z30 +24V supply sensor
z32 GND sensor

Analogue input

z8	channel 1	A14
z10	channel 2	B14
d10	channel 3	A15
z12	channel 4	B15
z32	analogue GND	A16 / B16

Analogue output

z16	Analogue out 1	A13
d16	Analogue out 2	B13
d18	Servo + (PWM current out)	
z18	Servo - (PWM current out)	
b28	monitor current out 4 – 20mA	
b6	flapper valve current out	

Digital input

d26 input 1
z26 input 2
d24 input 3
z24 input 4
d32 GND (external)

Digital output

z6 output 1
b8 output 2
b10 output 3
b12 output 4

Programming interface RS232

F48 pin	9pol D-Sub	function
b22	2	Tx
b24	3	Rx
b32	5	GND

Programming interface RS422

z2	Tx+
z4	Tx-
d4	Rx+
d6	Rx-
b32	GND

(Normally one does not need)

Front view

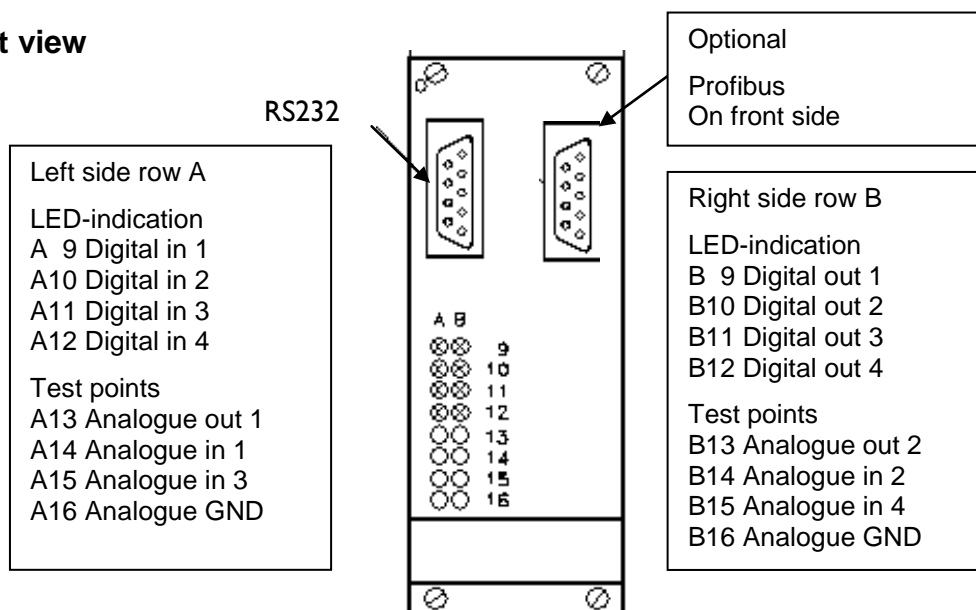

Layout diagram controller board

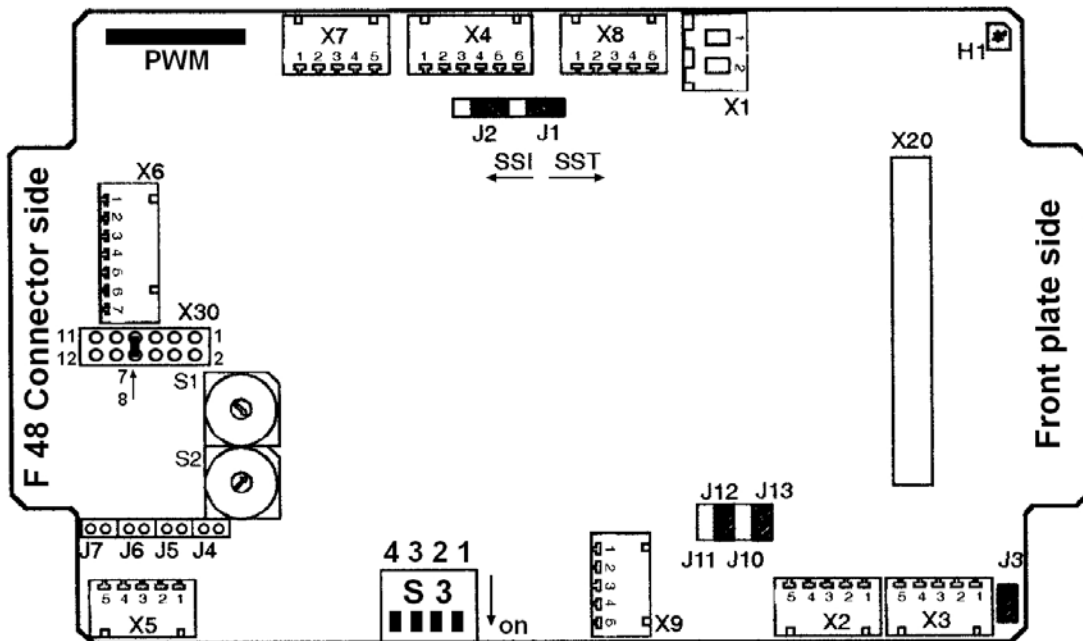

Jumper settings

S1 / S2	CAN address S1 CAN low S2 CAN high	
S3.1-4	4 chan. DIP-switch cold boot / download start / baud rate (down middle)	
S3.1	0 = run	1 = reset
S3.2	0 = run	1 = download mode
S3.3/4	Off / Off = 125 KB	On / Off = 250 kB
	Off / On = 500 KB	Off / On = 1000 KB
J1...J2	SSI / Start-Stop (above) J1 and J2 right = for SST-sensor (Start-Stop-sensor) J1 and J2 left = for SSI-sensor	
J3	CAN terminal resistance (down completely right) J3 out = open in = with 120 Ohm	
J4...J7	analogue current / voltage input selection (down left) J4 out = voltage in = current input for channel 1 J5 out = voltage in = current input for channel 2 J6 out = voltage in = current input for channel 3 J7 out = voltage in = current input for channel 4	
J10...J11	diagnostic port setting (down right) J10 and J11 out = Full-Duplex in = Half Duplex	
J12...J13	diagnostic port setting (down right) J12 and J13 out = open in = with 120 Ohm terminal resistance	
X30	Jumper field 7 - 8 connection DA1 to PWM-booster unit All other points must be open	
Led H1	(top right) off = no voltage flashing with 1 Hz = run (or download run) on = stop	

Layout diagram basic board

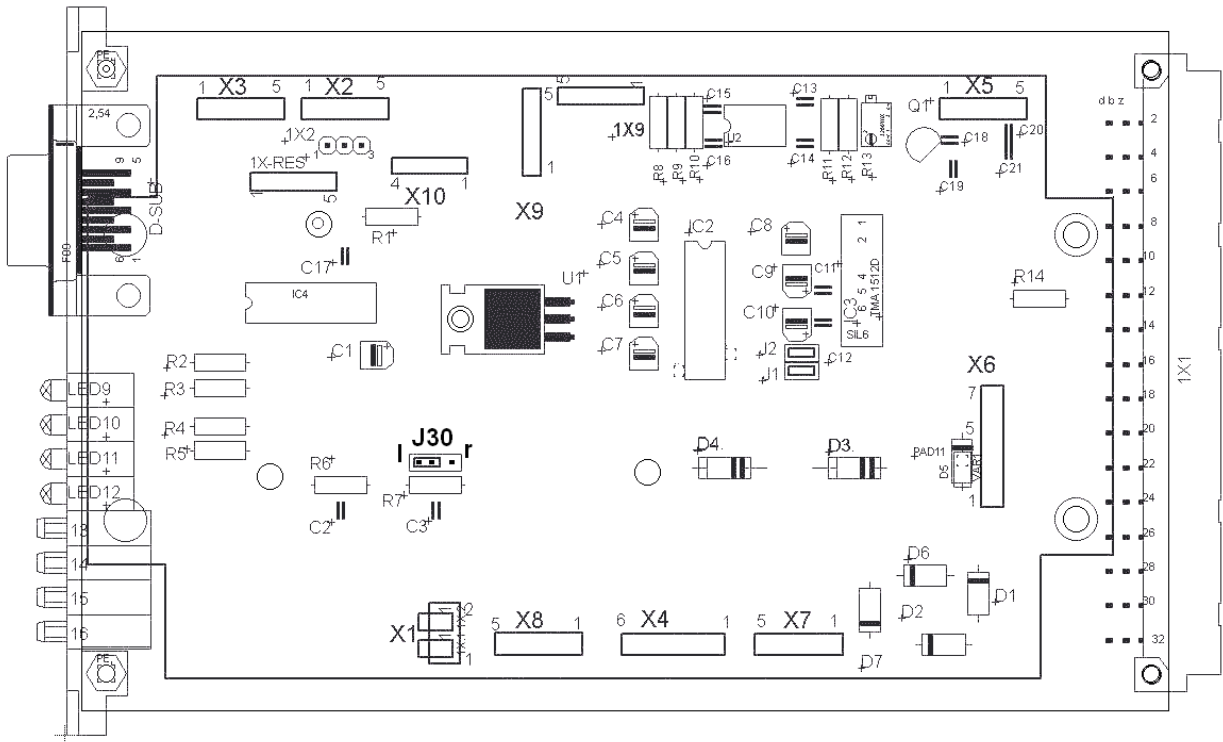

Jumper settings

- J30** Signal select for current monitor 4-20mA circuit IC4
 Left setting = A_{out1} is the source for IC4 (Test point A13)
 No setting = no connection
 right setting = A_{out2} is the source for circuit IC4 (Test point B13)

Layout diagram for optional Profibus add-on board

Connection via 9 pin D-SUB on front plate or direct terminal on the board
 A-line = Pin 3 B-line = Pin4 shield = Pin 5
 with Termination switch and address switch

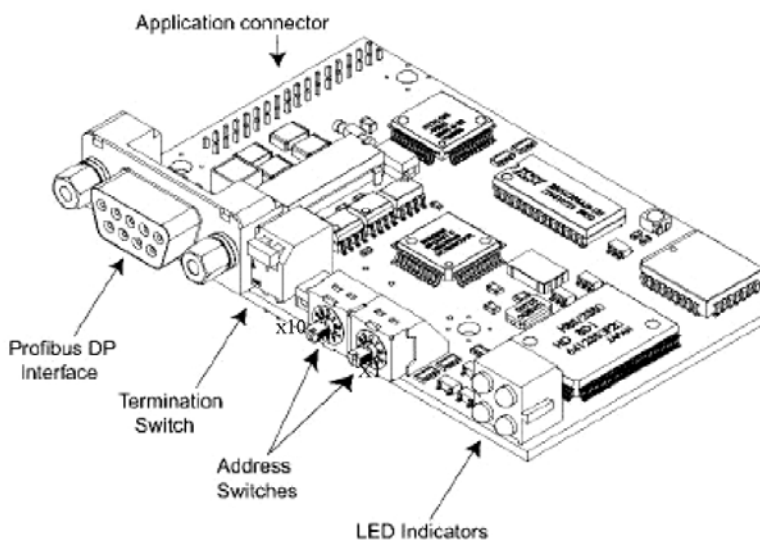

Address switch (00 ... 99)
 Left = x10; Right = x1

Indication LEDs

1	not used
2	green on = online ok off = not online
3	red on = offline off = not online
4	red flashing 1Hz error configuration flashing 2 Hz error parameter data flashing 4Hz error initialisation